



Hand Pallet Truck Capacity 2500 kg M 25

SERIES 032

Safety

At Linde, safety receives the closest attention in material handling trucks of every size. The wide handle of the Linde control tiller provides the operator with the necessary sense of safety, effectively protecting the hands throughout every maneuver, while the low-slung chassis prevents risk of foot injury.

Performance

Air- and dust-tight enclosure of the hydraulic circuit ensures troublefree operation over long periods of time, no matter how harsh conditions may be on site. With the fast-lift feature, loads weighing up to 150 kg can be lifted to maximum height in half the time. The M25 is a hand pallet truck for peak performance.

Comfort

The Linde M25 Hand Pallet Truck lives up to its purpose of a high-convenience all-around helper. Functional design devoid of all sharp corners and edges plus a large steering pivot angle of 110° to either side make it exceptionally manageable and maneuverable inside a trailer or in other tight spaces.



Reliability

Torsion-resistant construction of the strong chassis permits safe handling of loads up to 2500 kg, raising capacity 25 % above that of the customary standard 2000 kg truck. Long life is a built-in feature of the sturdy hydraulic lift unit housing, made as single-piece casting. The hard-wearing powder coat finish provides excellent protection from corrosion.

Productivity

Effective and cost-efficient at work. Steer and load wheels are of very high quality, quiet running and low in rolling resistance. Bush bearings are fitted on all joints, making it possible to all but forget about wear and maintenance.

Features

Linde control tiller

- Wide handle for effortless steering
- Optimum hand protection
- Convenient maneuvering due to 220° steering pivot angle
- Plastic handle covering affords pleasant and secure grip at all ambient temperatures

Chassis

- Sturdy, torsion-resistant steel construction
- Reinforced tiller base ensures long life
- High-grade powder coat finish

Fast-lift hydraulic lift unit

- Hydraulic circuit sealed air- and dust-tight to preserve smooth working characteristics
- Fast-lift feature as standard (active with loads up to 150 kg), lifts to maximum height in half the time

Smooth-running steer and load wheels

- Entry/exit rollers under the fork tips simplify pallet pick-up
- Tapered and ramped fork tips make pallet entry much easier, especially with stretch-wrapped loads
- Low rolling resistance

Small servicing requirements

- All joints fitted with bush bearings as standard
- Hardly any need to think about wear and maintenance



Equipment

Standard

Truck

- Nylon wheels of low rolling resistance
- Single load wheels
- Truck width 530 mm
- Ergonomic, plastic-covered Linde comfort-class control tiller
- Steering pivot angle 110 degrees to either side
- Packaged, enclosed lift unit
- Fast lift for loads up to 150 kg
- Overload relief valve

Options

- Truck width 685 mm
- Other fork lengths
- Solid rubber or polyurethane steer wheels
- Tandem load wheels
- Polyurethane load wheels
- Fork lengths 1500, 1800 or 2000 mm



M25 (in mm)		
Capacity	kg	2500
Load center	c	600
Lift	h3	120
Lowered height	h13	85
Fork length	l	800, 900, 1000, 1150
Overall length	l1	1560
Overall width	b1	530, 685
Fork spread	b5	530, 685
Fork width	e	150
Turning radius	Wa	1361
Working aisle width	Ast	1811
Steer wheel	ø	200x50
Fork rollers	ø	80x60 (tandem)
Truck weight	kg	79

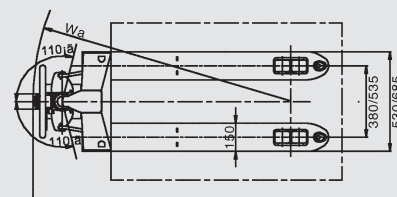
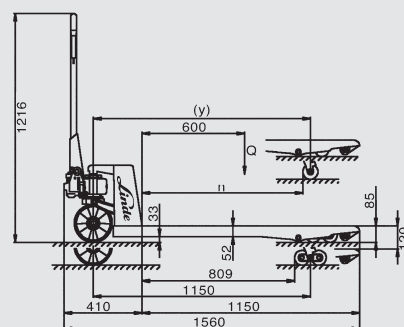

Subject to change in the interests of progress. Illustrations and technical details non-binding. All dimensions subject to customary tolerance.

