



Diesel and LPG Forklift Trucks Capacity 2500 – 3500 kg H 25, H 30, H 35

SERIES 393



Linde Material Handling

Linde

Safety

Linde ProtectorFrame: Overhead guard and frame form a structural unit, resulting in maximum stability and safety. Top-mounted tilt jacks allow use of slim mast upright sections for optimum visibility.

Performance

Advanced engine and drive technology combined with the original Linde Load Control system enables the operator to use the truck's vast potential to maximise productivity. Comfortable and precise fingertip control of all mast functions.

Comfort

Linde brings to this forklift a generously sized automobile-class workspace. Designed to the most advanced ergonomic standards. Spacious cab interior, adjustable armrest, suspension seat and functional positioning of easy-actuation controls: basic to fast, stress-free working.

Reliability

Proven in tough sustained operation. Isolation of the cab from the mast, drive axle and chassis results in reduced shock and vibration. Maintenance-free mounting of axles and tilt jacks cuts downtime and operating costs.

Productivity

Effective and costefficient at work: The original Linde hydrostatic drive cost does away with gearshift, clutch, differential and drum brakes. As a result, servicing costs are low, truck uptime is high and productivity is enhanced.

Technical data

Characteristics	1.1	Manufacturer		LINDE
	1.2	Model designation		H25D
	1.3	Power unit: battery, diesel, petrol, LP gas, mains power		Diesel
	1.4	Operation: manual, stand-on, seated		Seated
	1.5	Load capacity	Q (kg)	2500
	1.6	Load centre	c (mm)	500
	1.8	Axle centre to fork face	x (mm)	445
	1.9	Wheelbase	y (mm)	1905
	Weight	2.1	Service weight	kg
2.2		Axle load with load, front/rear	kg	5670/700
2.3		Axle load without load, front/rear	kg	1930/1940
Wheels and tyres	3.1	Tyres: solid rubber, superelastic, pneumatic (P)		SE
	3.2	Tyre size, front		27 x 10 - 12 ¹⁾
	3.3	Tyre size, rear		23 x 9 - 10 ⁴⁾
	3.5	Wheels, number front/rear (x = driven)		2 x (4x)/2 ²⁾
	3.6	Track width, front	b10 (mm)	1008 (1204) ²⁾⁵⁾
	3.7	Track width, rear	b11 (mm)	932
	Dimensions	4.1	Mast lift, forward/backward	α/β (°)
4.2		Height of mast, lowered	h1 (mm)	2264 ³⁾
4.3		Free lift	h2 (mm)	150
4.4		Lift	h3 (mm)	3050
4.5		Height of mast, extended	h4 (mm)	3840
4.7		Height of overhead guard	h6 (mm)	2210
4.8		Height of seat	h7 (mm)	1105
4.12		Towing coupling height	h10 (mm)	698
4.19		Overall length	l1 (mm)	3727
4.20		Length to fork face	l2 (mm)	2727
4.21		Overall width	b1/b2 (mm)	1256 ⁶⁾
4.22		Fork dimensions	s/e/l (mm)	45 x 100 x 1000
4.23		Fork carriage to DIN 15173, class/form A, B		2A
4.24		Width of fork carriage	b3 (mm)	1150 ⁷⁾
4.31		Ground clearance, mast	m1 (mm)	119
4.32		Ground clearance, centre of wheelbase	m2 (mm)	173
4.33		Aisle width pallet 1000 x 1200 across forks	Ast (mm)	4065
4.34		Aisle width pallet 800 x 1200 along forks	Ast (mm)	4265
4.35		Turning radius	Wa (mm)	2420
4.36		Minimum pivoting point distance	b13 (mm)	580
Performance	5.1	Travel speed, with/without load	km/h	22/22
	5.2	Lifting speed, with/without load	m/s	0.47/0.48
	5.3	Lowering speed, with/without load	m/s	0.52/0.54
	5.5	Tractive force, with/without load	N	19790/15150
	5.7	Climbing ability with/without load	%	32/33
	5.9	Acceleration time, with/without load	s	5.6/4.8
5.10	Service brake		hydrostatic	
Drive	7.1	Engine manufacturer/type		VW/CBHA (EWG)
	7.2	Engine performance according to ISO 1585	kW	44
	7.3	Rate speed	min ⁻¹	2800
	7.4	Number of cylinders	cm ³	4/1968
	7.5	Fuel consumption according to VDI cycle	l/h; kg/h	3.2
Others	8.1	Type of drive control		hydrost. infinitely variable
	8.2	Working pressure for attachments	bar	170
	8.3	Oil flow for attachments	l/min	32
	8.4	Noise level, at operator's ear	dB(A)	77
	8.5	Towing coupling, design/type		DIN 15170 H

1) Optionally 7.00 - 12 twin tyres (P and SE), single tyres Luft 27 x 10 - 12 and SE 28 x 12.5 - 15

2) Figures in parentheses for twin tyres

3) With 150 mm free lift on standard mast

4) Figures in parentheses for duplex and triplex masts

5) 1042 mm for SE 28 x 12.5 - 15 tyres

6) 1337 mm for SE 28 x 12.5 - 15 tyres; 1264 mm for P250/75 R12 tyres; 1617 mm for P250/75 R12 tyres; 1617 mm for P250/75 R12 tyres

7) Optionally pneum. 23 x 9 - 10

8) Lift height and equipment can alter r

LINDE	LINDE	LINDE	LINDE	LINDE
H25T	H30D	H30T	H35D	H35T
LPG	Diesel	LPG	Diesel	LPG
Seated	Seated	Seated	Seated	Seated
2500	3000	3000	3500	3500
500	500	500	500	500
445	445	445	450	450
1905	1930	1930	1965	1965
3850	4220	4200	4680	4665
5630/720	6420/800	6380/820	7240/940	7205/960
1890/1960	1950/2270	1910/2290	2050/2630	2015/2650
SE	SE	SE	SE	SE
27 x 10 - 12 ¹⁾	27 x 10 - 12 ¹⁾	27 x 10 - 12 ¹⁾	27 x 10 - 12 ¹⁾	27 x 10 - 12 ¹⁾
23 x 9 - 10 ⁴⁾	23 x 9 - 10 ⁴⁾	23 x 9 - 10 ⁴⁾	23 x 9 - 10 ⁴⁾	23 x 9 - 10 ⁴⁾
2 x (4x)/2 ²⁾	2 x (4x)/2 ²⁾	2 x (4x)/2 ²⁾	2 x (4x)/2 ²⁾	2 x (4x)/2 ²⁾
1008 (1204) ²⁾⁵⁾	1008 (1204) ²⁾⁵⁾	1008 (1204) ²⁾⁵⁾	1008 (1204) ²⁾⁵⁾	1008 (1204) ²⁾⁵⁾
932	932	932	932	932
5.0/8.0 ⁸⁾	5.0/8.0 ⁸⁾	5.0/8.0 ⁸⁾	5.0/8.0 ⁸⁾	5.0/8.0 ⁸⁾
2264 ³⁾	2264 ³⁾	2264 ³⁾	2264 ³⁾	2264 ³⁾
150	150	150	150	150
3050	3050	3050	3050	3050
3840	3840	3840	3840	3840
2210	2210	2210	2210	2210
1105	1105	1105	1105	1105
698	698	698	690	690
3727	3755	3755	3795	3795
2727	2755	2755	2795	2795
1256 ⁶⁾	1256 ⁶⁾	1256 ⁶⁾	1256 ⁶⁾	1256 ⁶⁾
45 x 100 x 1000	45 x 100 x 1000	45 x 100 x 1000	50 x 120 x 1000	50 x 120 x 1000
2A	3A	3A	3A	3A
1150 ⁷⁾	1150 ⁷⁾	1150 ⁷⁾	1150 ⁷⁾	1150 ⁷⁾
119	119	119	117	117
173	173	173	172	172
4065	4089	4089	4126	4126
4265	4289	4289	4326	4326
2420	2444	2444	2476	2476
580	580	580	580	580
22/22	22/22	22/22	22/22	22/22
0.47/0.48	0.47/0.48	0.47/0.48	0.47/0.48	0.47/0.48
0.52/0.54	0.52/0.54	0.52/0.54	0.52/0.54	0.52/0.54
20030/15150	19790/15300	19790/14990	19790/16090	19790/15810
32/33	27/30	26/30	24/28	23/28
6.0/5.2	5.6/4.8	6.1/5.3	5.7/4.9	6.1/5.3
hydrostatic	hydrostatic	hydrostatic	hydrostatic	hydrostatic
VW/BEF	VW/CBHA (EWG)	VW/BEF	VW/CBHA (EWG)	VW/BEF
39	44	39	44	39
2600	2800	2600	2800	2600
4/1984	4/1968	4/1984	4/1968	4/1984
2.9	3.4	3.0	3.6	3.2
hydrost. infinitely variable	hydrost. infinitely variable	hydrost. infinitely variable	hydrost. infinitely variable	hydrost. infinitely variable
170	170	170	170	170
32	32	32	32	32
77	77	77	77	77
DIN 15170H	DIN 15170H	DIN 15170H	DIN 15170H	DIN 15170H

1611 mm for SE 7.00 - 12 twin tyres; 1271 mm for P 27x10 - 12/20PR tyres;
14 mm for P 7.00 - 12/16 PR twin tyres; 1630 mm for 7.00 R10 twin tyres

rear mast tilt angle

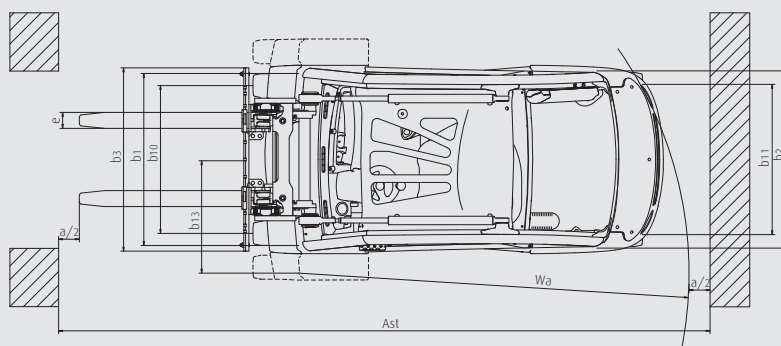
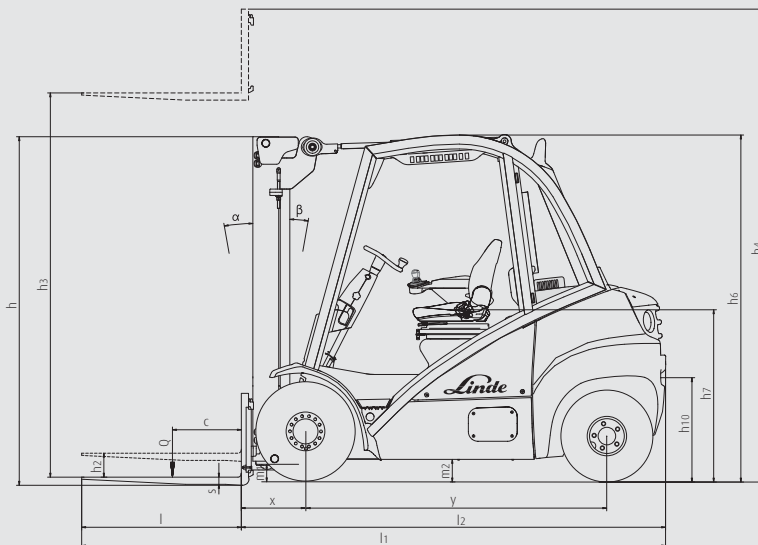

Lifting capacity diagrams

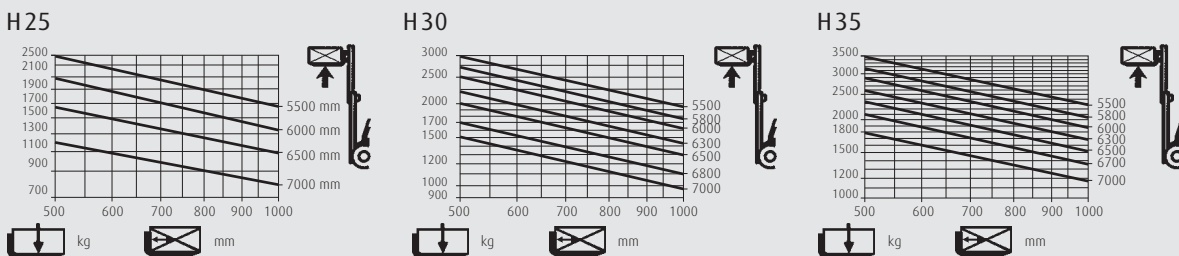

For Standard and Duplexmasts with standard equipment.

Overall height and lift heights, Standard (in mm)

Height of Mast, lowered	h1	2264	2414	2564	2714	2964	3214	-
Free lift	h2	150	150	150	150	150	150	-
Lift	h3	3050	3350	3650	3950	4450	4950	-
Height of Mast, extended	h4	3840	4140	4440	4740	5240	5740	-

Overall height and lift heights, Duplex (in mm)

Height of Mast, lowered	h1	2190	2490	2640	-	-	-	-
Free lift	h2	1424	1724	1874	-	-	-	-
Lift	h3	3115	3715	4015	-	-	-	-
Height of Mast, extended	h4	3905	4505	4805	-	-	-	-

Overall height and lift heights, Triplex (in mm)

Height of Mast, lowered	h1	2191	2241	2491	2641	2841	-	-
Free lift	h2	1424	1474	1724	1874	2074	-	-
Lift	h3	4655	4805	5505	5955	6455	-	-
Height of Mast, extended	h4	5445	5595	6295	6745	7245	-	-

Alternative lift heights available on request.

Standard and optional equipment

Standard equipment

Truck

Linde twin drive pedals to control forward/reverse travel and braking

Linde Load Control integrated in armrest

Hydraulic-suspension comfort-class seat with extensive range of adjustment

Adjustable-angle steering wheel

Low-effort, responsive and virtually play-free hydrostatic steering with on-demand power assist

High safety and stability ensured by Linde ProtectorFrame

Air intake filter with integral cyclone separator

High-performance hydraulic filter concept, preserves maximum oil purity and extends life of all hydraulic components

Anti-glare display including fuel gauge, clock, hour meter and servicing information

Control lights on display for engine oil pressure, engine overheating, parking brake, audible warning signal for engine and hydraulic oil temperature, blocked intake filter and low fuel level

Plenty of storage space for writing utensils, beverage cans, etc.

Superelastic tyres

LPG truck fitted with two-way catalytic converter and the gas cylinder mount is ergonomically designed for easy changing

LPG truck is fitted with accurate ultrasonic fuel level indicator for exchange cylinders

LPG volumetric fuel tank version has a fuel level indicator in the display console

Mast

Standard mast lift height $h_3 = 3,050$ mm

Standard, duplex and triplex masts

Top-mounted tilt jacks

Zero-maintenance mast and tilt jack cylinder mounting

Rubber-mounted joints

Electronic tilt angle limiting

Fork length $l = 1,000$ mm

Fork carriage width $b_3 = 1,150$ mm

Options

Single drive pedal with direction selector positioned on armrest

Standard masts from 3,150 mm to 6,550 mm lift

Duplex masts (full free lift) from 3,165 mm to 4,765 mm lift

Triplex masts (full free lift) from 4,705 mm to 6,455 mm lift

Integral sideshift

Load backrest

One or two auxiliary hydraulic circuits for all mast types

Alternative fork lengths

Overhead guard can be upgraded to full cabine with roof, front and rear screens and doors (also available with tinted glass)

Wiper-washers for front, rear and roof screens

Seats providing additional comfort and adjustments

Cab heater with integral pollen filter

Radio with cassette player and speakers

Truck lighting, work lamps

Mirrors

Highway specifications

Integral diesel particulate filter with charge status indicator on the display console

Air precleaner

Audible reversing alarm, flasher and strobe beacons

Biodiesel (RME) fuel version

Custom paintwork

Other options available on request

Features

Original Linde hydrostatic drive

- Responsive, smooth and precise driving
- No clutch, differential or drum brakes; hydrostatic drive assumes function of service brake
- Robust drive system, well proven in severest duty
- Low maintenance costs and long life



Linde ProtectorFrame

- Safe and robust chassis, enclosed on all sides
- Engine hood and servicing doors open wide for convenient access to all components

Linde twin drive pedals

- Quick change of forward/reverse direction without changing feet on pedals
- Short pedal stroke
- No leg fatigue
- Increased productivity

Linde Load Control

- Accurate, safe load handling
- Effortless fingertip control of all mast functions
- Traction and lift functions completely separate

High-economy engine technology

- Diesel and LPG engines incorporating most advanced technology
- High torque
- Low fuel consumption
- Low exhaust gas and soot emission levels



Linde operator compartment

- Designed to advanced ergonomic standards
- Spacious cab with automobile-equivalent legroom
- Excellent visibility of load and surroundings due to slim-line mast sections
- Cushioned drive axle reduces road shock
- Minimum driving noise

Linde Truck Control

- Reliable electronic controller
- Easily matched to individual requirements
- High dependability resulting from redundant monitoring systems
- Automatic control of engine speed as function of load
- Casing totally enclosed for protection from dust and dirt

Linde clear-view mast

- Superb visibility through slim-profile sections of mast
- Full load capacity up to maximum lift height
- Exceptional residual capacity
- Zero-maintenance rubber mounting of mast and tilt jacks
- Electronic limiting of tilt angle

Subject to modification in the interests of engineering progress. Illustrations and technical details non-binding for actual construction. All measurements subject to customary tolerances.